

Conductor system 4-Ductor[®]

Insulated conductor system
for 4 conductors

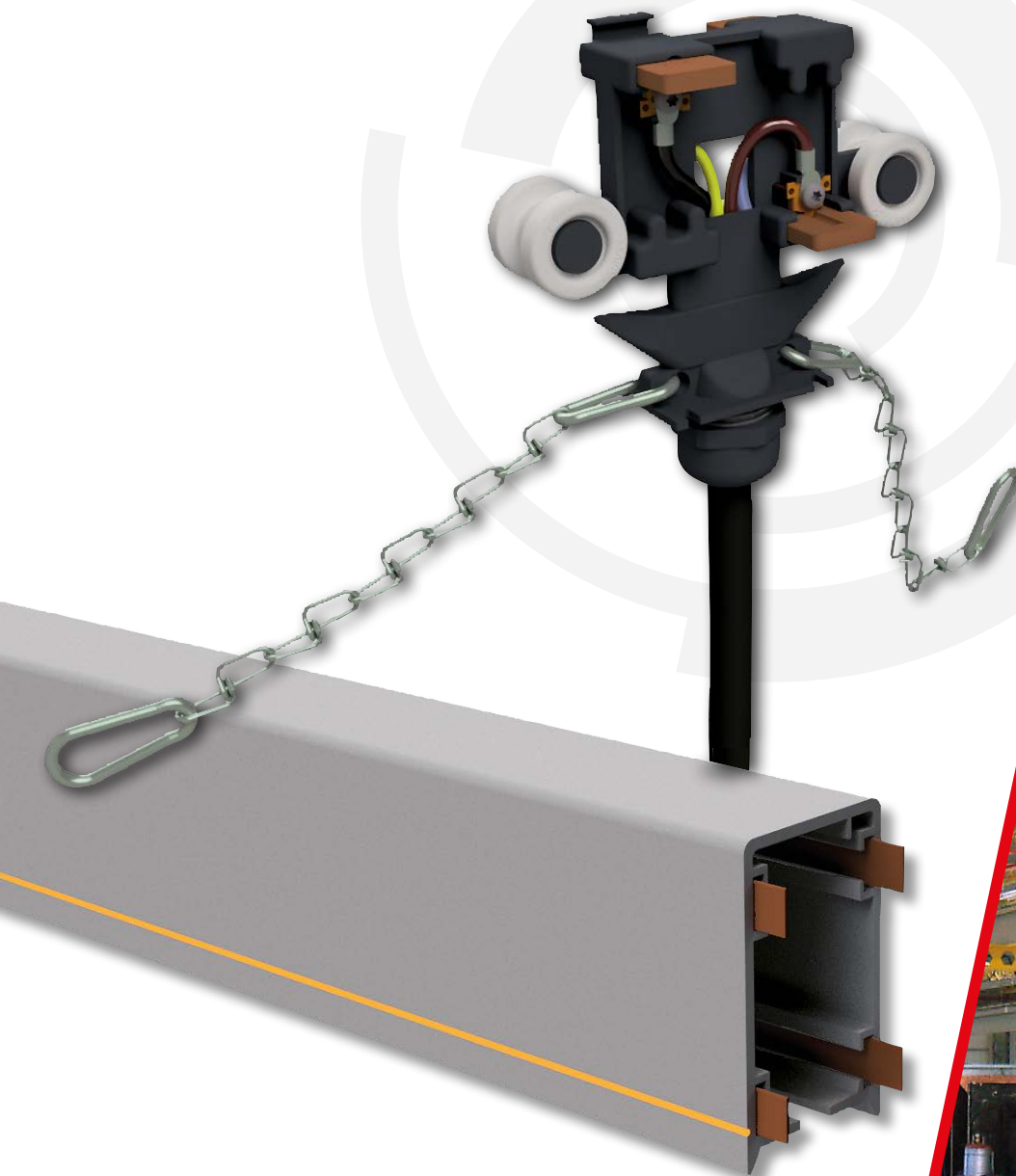

4-Ductor[®] current supply system

compact, reliable and safe!

Akapp-Stemmann 4-Ductor is a compact, reliable and safe current supply system for cranes, hoists, monorail systems, conveyor belts and many more applications.

The flat, **jointless** copper strips are retracted from rolls over the entire length of the track.

The 4-Ductor has many unique properties, which are characteristic of the Akapp-Stemmann principle of the continuous copper strip. Its many advantages are described below.

Which advantages does 4-Ductor[®] offer you?

• **Excellent price/quality ratio.** The concept of the continuous conductors and the use of only high quality components result in a trouble free feeding system against an agreeable price.

• **Continuous copper conductors.** The flat copper conductors can be pulled from rolls into the previously installed PVC housing in long continuous lengths, without any connections in the conductor.

• **High current capacity.** Copper conductors of various capacities can be pulled into the channels in the housing. Standard conductor capacities are 35, 50, 80, 125 and 160A.

• **Simple installation.** Due to the light weight of the PVC housing, copper conductors without connections and the design of accessory components, system installation is a quick and easy operation.

• **Virtually maintenancefree.** The PVC housing needs no maintenance and as previously mentioned continuous copper conductors ensure minimal brush wear. Thus minimising the presence of carbon deposits. Inspection periods can be scheduled in line with the schedule of the apparatus to be fed (i.e. a crane).

• **Voltdrop absolute minimum and constant** due to continuous copper conductors, thus avoiding problems associated with added resistance at joints and increased volt drop characteristics when joints loosen or corrode.

• **Compact design.** By virtue of design, the 4-Ductor system utilises an absolute minimum of space.

• **High mechanical strength.** The PVC housing has a combination of high flexural yield, impact and tensile strength and is complemented by the design of associated components.

• **Maximum power transmission.** The brushes are positively located in the PVC housing and contact with the flat copper conductors is maintained by spring pressure. This guarantees a positive contact and excellent power transmission.

• **Exceptionally long carbon brush life** is achieved due to the absence of conductor joints and connections which ensures trouble free operation.

• **Safety to personnel.** The high level of volume resistivity of the PVC housing ensures absolute safety to personnel. Protection degree of the housing is IP23.

• **No expansion problems.** Due to the clearance that exists between the conductors and their location and the clearance between the PVC housing and sliding hangers, expansion due to changes in ambient temperature is accommodated without affecting the operation of the system.

This also applies to extra long installations where standard components eliminate expansion problems often experienced with alternative systems.

For some applications, it is necessary to use the **Akapp-Stemmann Multiconductor[®] system** (please refer to separate brochure). Typical examples are as follows:

- 5 to 7 conductors are to be installed in one housing;
- sealing of the housing against dust, moisture and vapors is necessary (protection class Multiconductor with flexible sealing strips AS7 is IP44);
- the installation requires the use of transfer guides or isolation sections;
- the travel speed is in excess of 250 m/min.;
- a combination of the above.

Please note that, due to continuous innovations, technical specifications and performances listed in this catalogue, are subject to change without notice. Wabtec Netherlands B.V. cannot be held liable for any damage whatsoever resulting from the use of the information in this brochure.

4-Ductor[®] housing and copper

uninterrupted reliability!

The conductor housing RN4 has 4 slots to accommodate copper conductors.

Colour: grey (appr. RAL 7001)

Temperature range -30°C to +60°C.

The PVC, with a high impact strength, is self-extinguishing.

Protection class of the conductor housing is IP23.

The anti-reverse rib (A) in the housing ensures that the collector trolley can only be installed in one way and prevents cross phasing. A continuous yellow stripe (B) on one side of the housing ensures correct fitting of the system.

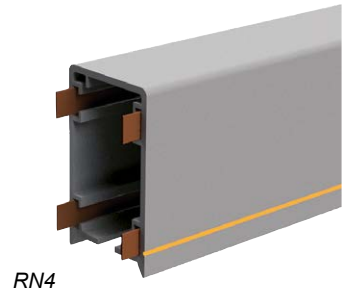

RN4

Technical data of the housing

Material data	
Unplasticized Hard-PVC with approximate values:	
Notch shock strength	5-10 kJ/m ²
E-modulus	2500-3000 N/mm ²
Softening point (Vicat)	81-83°C
Linear expansion	70.10 ⁻⁶ m/m/°C
Electrical data	
Volume resistivity with 100V	>4.10 ¹⁵ Ω/cm
Dielectric strength with 50 Hz	>30 kV/mm

Length of housing is standard 4 m; Special lengths are available.

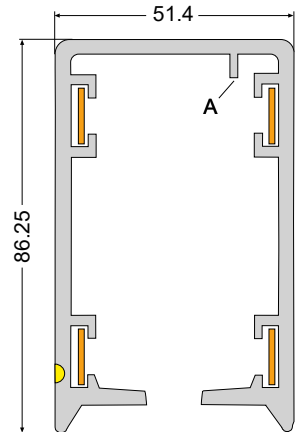

AKAPP NO.	DESCRIPTION	max. travel speed (m/min.) *	combined with curves	combined with transfer guides	extra HS protection
1001390	PVC housing, grey RN4	250	x	-	-

*) Depending on the configuration of the installation and the collector trolley(s)

Copper conductors for housing RN4

Each 4-Ductor installation is supplied with continuous flat copper conductors to suit the system length.

Copper conductors type CU35, CU50, CU80, CU125 and CU160 for current capacities 35, 50, 80, 125 and 160A (duty cycle 80%) Material electrolytic copper.

Application of **silver-plated** copper is also possible (advantageous for data transfer!).

Maximum lengths of continuous conductor strip that can be pulled into the conductor housing: CU35: 60m; CU50: 525m; CU80: 325m; CU125: 200m; CU160: 150m.

Installation of the copper conductors

Following the installation of the conductor housings the flat copper conductors can easily be drawn into the copper channels directly from the cable drum. This can be easily and quickly effected by means of the copper pulling cassette and pulling block, available as an option.

A simple stretchblock is supplied for conductors CU125 and CU160. This is designed to make installation easier and also to reduce any resistance on very long installations.

Volt drop in copper conductors.

By virtue of the continuous conductor concept, Volt drop in the 4-Ductor system is kept to an absolute and constant minimum. With a power factor (cos. φ) of < 1 the figures mentioned in the adjacent table have to be changed accordingly, e.g. with cos φ = 0.85 the Volt drop figures have to be multiplied by 0.85.

35A	—————
50A	—————
80A	—————
125A	—————
160A	—————



For applications where higher temperatures exist, the resistance, and therefore the Volt drop, increases.

Solution: using next size copper conductors.

Volt drop in V /meter 4-Ductor/ A nominal current, cos φ = 1, +20 °C ambient temp.

copper conductor	3 phase ~	1 phase ~ en =	When utilizing 2 copper conductors in parallel the volt drop values in the table will be halved. On request, impedance data can be supplied
CU35 *	0.00588	0.00679	
CU50	0.00339	0.00391	
CU80	0.00217	0.00251	
CU 125	0.00119	0.00138	
CU 160	0.00092	0.00106	
with + 35 °C multiply by 1.079;			
with + 45 °C multiply by 1.118;			
with + 55 °C multiply by 1.157.			

* Copper conductors 35A can not be combined with expansion joints

AKAPP NO.	DESCRIPTION	max. I _n (DC=80%) (A)	dimension mm (b x d)	linear exp. K-6 10 ⁻⁶ m/m/°C	DC resistance Ω/m	specific conductance (ρ) Sm/mm ²	max. length track part (m)	max. speed (m/min.)
1002170	Copper conductor 35A CU35	35	12.7 x 0.4	17.00	0.003444882	58	60	80
1002560	Copper conductor 50A CU50	50	12.6 x 0.7	17.00	0.001984127	58	525	500
1002640	Copper conductor 80A CU80	80	12.5 x 1.1	17.00	0.001272727	58	325	500
1002720	Copper conductor 125A CU125	125	12.5 x 2.0	17.00	0.0007	58	200	500
1002870	Copper conductor 160A RN7 CU160/7	160	12.5 x 2.6	17.00	0.000538462	58	150	500
1003370	Copper conductor silv. 50A CU50/AG	50	12.6 x 0.7	17.00	0.001984127	58	525	500

Hanging and fixing of the housing

free expansion at all times!

The principle of the Akapp-Stemmann conductor bar systems with uninterrupted conductors is based on the free expansion of the pvc housing and the internal conductors. The conductor housing is therefore suspended in sliding hangers in which these conductors - upon the occurrence of differences of expansion - can slide continuously and who are fixed at the feed point only by means of a **fixed point clamp** at the construction.

Sliding hangers and fixed point clamps are made of sendzimir galvanized steel, for use in indoor installations under normal operating conditions.

For outdoor installations we recommend using our Multiconductor system (see also page 2 below right).

Sliding hanger

Type BN7-Z

The sliding hangers are fastened to the suspension frame by means of a bolt. As such the installation can be **aligned vertically**.

Centre distance of hanger supports:

Type copper conductor	No. conduct.	Speed <250 m/min.		Speed >250 m/min.
		$\Delta T < 40 \text{ }^\circ\text{C}$	$\Delta T > 40 \text{ }^\circ\text{C}$	
CU35 - CU50 - CU80	4	2000mm	2000mm	1000mm
Cu125 - Cu160	4	1333mm	1333mm	1000mm

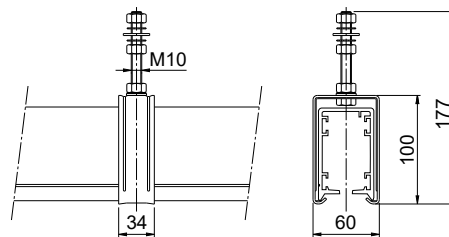

BN7-Z + UH...

Fixed point clamp

Type VMN7-Z

The complete conductor installation is to be fastened to the suspension frame by means of a self-gripping fixed point clamp. As of this location, the conductor housing can slide freely in the sliding hangers when expansion differences, due to temperature variation, occurs.

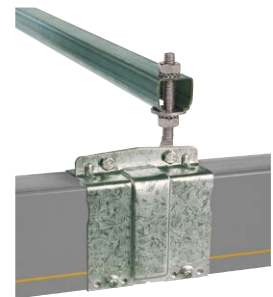
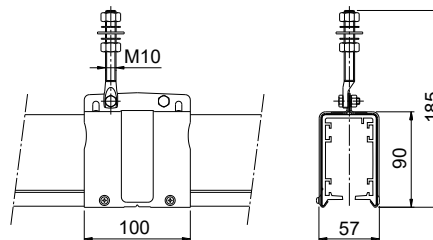

VMN7-Z + UH...

Support bracket

Type UH330 : l=330 mm, galvanised

Type UH500 : l=500 mm, galvanised

Type UH700 : l=700 mm, galvanised

Special length on request. These brackets have clamps attached to sliding nut assemblies thus facilitating a flexible mounting arrangement, capable of accommodating various sizes of RSJ (INP) beams and allowing simple **horizontal alignment**.

Note: For fast mounting on site, **pre-mounted** support brackets with sliding hanger are available on request. Please ask our sales department.

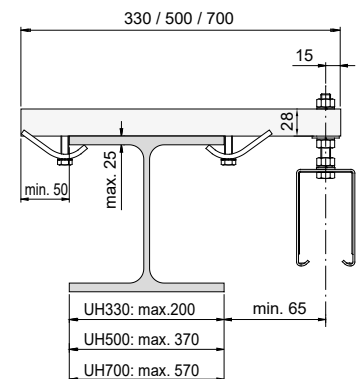
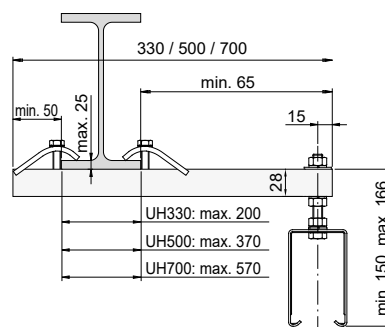

AKAPP NO.	DESCRIPTION	ambient is		
		dry	humid	chem. agr.
1004570	Sliding hanger galvanised BN7-Z	x		
1004960	Fixed point clamp galvanised VMN7-Z	x		

AKAPP NO.	DESCRIPTION	length (mm)
1018010	Support bracket galvanised 330mm UH330	330
1018160	Support bracket galvanised 500mm UH500	500
1018320	Support bracket galvanised 700mm UH700	700

Joint clamps

for easy connection of conductor housings

The lengths of the housing are connected by means of standard joint clamps. There are 2 variations:

- standard metal joint clamp (type VN7-Z)
- ABS expansion joint clamp (type KEV7).

Metal joint clamps VN7-Z are made of sendzimir galvanized steel, for use in indoor installations under normal operating conditions.

For outdoor installations we recommend using our Multiconductor system (see also page 2 below right).



VN7-Z

Joint clamp

Types VN7-Z

The conductor housings are connected by means of a self-gripping joint clamp.

The self-drilling screws, as supplied, ensure an extra firm connection with longer system lengths (from 80 m length 2 pc. per joint; from 200 m length 4 pc. per joint).

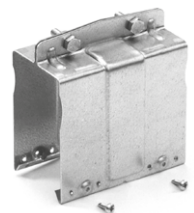
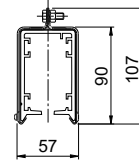
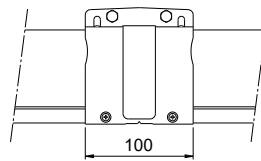

VN7-Z

Insulating tape

Type T50 (50 mm width, roll of 10 m)

This adhesive tape is used to ensure a permanent shroud around the housing joints, prior to fitting the joint clamps, for both indoor and outdoor installations.

1 roll is sufficient for 35 joints.

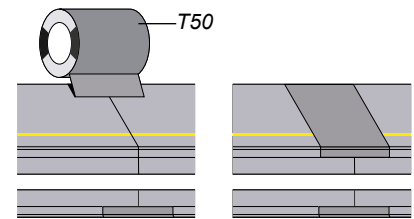

Expansion joint

Type KEV7

This ABS expansion joint is applied when a free expansion of the 4-Ductor from one fixed point is not possible. E.g. with very long installations, tracks in which there are several current supply connections, closed curved tracks, etc.

The PVC housing is then fixed to the support construction with a fixed point clamp adjacent to an expansion gap at recommended positions. The differences in expansion with temperature variation are compensated in the expansion joint sleeve by an expansion gap between the lengths of railhousings.

Important:

Copper strips **from CU50** required when using **expansion joints**.

Read the supplied mounting instructions carefully **before** mounting, to determine the expansion gaps. If in doubt, please consult your Akapp-Stemmann supplier.

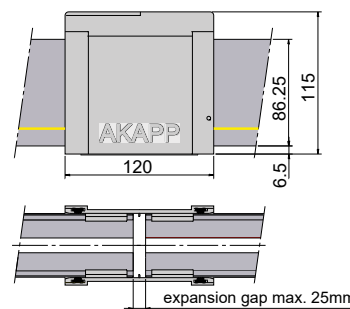

Installations with expansion joints require collector trolleys type “../E” (see page 9).

The rubber sealing at the inner side of the synthetic expansion joint clamp also allows **installations outdoors**, if the seal class IP23 is sufficient.

AKAPP NO.	DESCRIPTION	ambient is			with VN7-	max. free expansion in joint (mm)
		dry	humid	chemical aggressive		
1004730	Joint clamp galvanised VN7-Z	x				0
1006040	Insulating tape 10m x 50mm T50				x	0
1005461	Expansion joint KEV7	x	x	x		25

End feed boxes

efficient and reliable solutions

End feed boxes are used for the connection of the feeding cable to the outer end of the 4-Ductor system.

All feed boxes are fitted with metric glands. It is possible to use extra glands and/or several diameter ranges from type EB40.

End feed clamps are required for connection of copper conductors 125A or 160A (see details below).

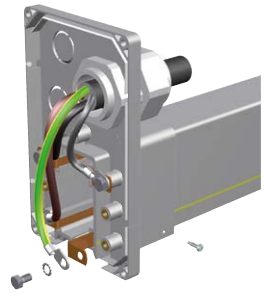

EB40 (open)

End feed boxes

Type EBS32

Compact end feed box with cable gland M32, suitable for cables Ø18-Ø21 mm. Connecting screws M6 included.

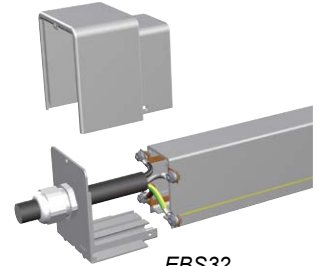
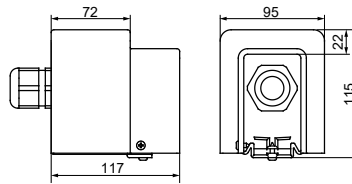

EBS32

Type EB40

End feed box for with cable gland M40, suitable for cables Ø22-Ø27 mm. The push-through holes offer easy mounting of various cable glands. Connecting screws M6 included.

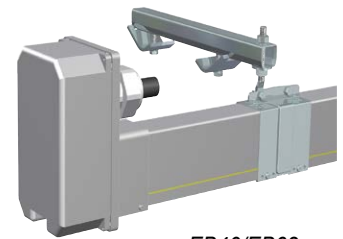
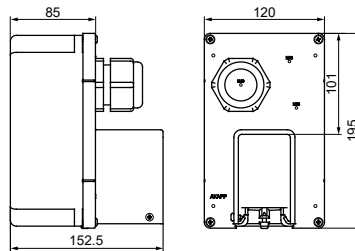

EB40/EB63

Type EB63

As end feed box EB40, but with cable gland M63, suitable for cables Ø37-Ø44 mm. Connecting screws M6 included.

End feed clamp

Type EC160

Required for connecting copper conductors 125A or 160A to the cable lug of the connection cable. To be ordered separately.

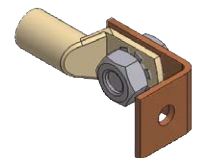
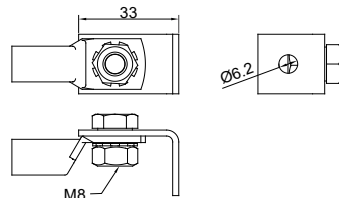

EC160

End cap

Type EN4

Length 300 mm. Attached to the housing by means of a joint clamp (to be ordered separately). See photo.

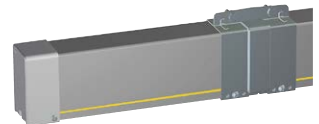
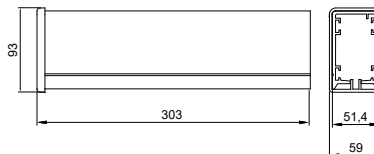

EN4 + VN7-Z

Special arrangements and gland sizes on request.

AKAPP NO.	DESCRIPTION	max. temp. (°C)	diameter range feeding cable (mm)	max. copper conductors mounted	I _{max} (80% DC non-parallel (A))	protection degree
1006830	End feed box with 1xM32	80	18-21	4xCU80	80	IP23
1006800	End feed box with 1xM40	80	22-27	4xCU125	125	IP23
1006810	End feed box with 1xM63	80	37-44	4xCU160	160	IP23
1006820	End feed box	80	no glands			IP23
1013010	End feed clamp	80			160	
1011890	Line feed box 1xM20/1xM16	80	1x 7-12 - 1x 5-8	4xCU50 / 4xCU80 *)	80	IP23
1006900	Line feed box 1xM40	80	22-27	4xCU125	125	IP23
1006910	Line feed box 1xM63	80	37-44	4xCU160	160	IP23
1006940	Line feed box	80	no glands			IP23
1006030	Line feed clamp holder	80				
1006950	Set line feed	80				
1014100	End cap grey	60		4		IP23

*) When using additional glands M20

Line feed boxes

designed for more flexibility

Lines feed boxes are used for the connection of the feeder cable on any random point of the system. The feeder cable is connected to line feed clamps, kept in place by the line clamp holder that is partly slid over the 2 housing parts in which up to 4 line feed clamps (see picture) can be fitted. The copper conductors will not be interrupted!

Basis of the line feed boxes is the modular collar that is fitted with push through holes to fit various glands.

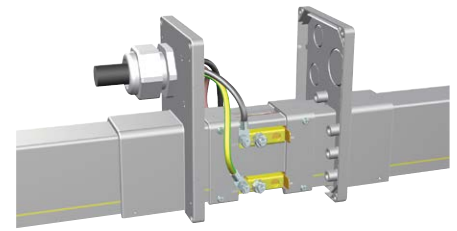

LCH + LC80

Line feed boxes types LB

Type LBS

Line feed box for connection of copper conductors up to 80A. With 1 gland M20 for cables Ø7-Ø12 mm and 1 gland M16 for cables Ø5-Ø8 mm.

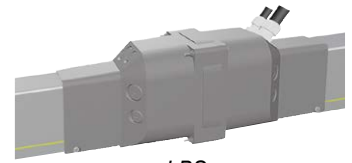
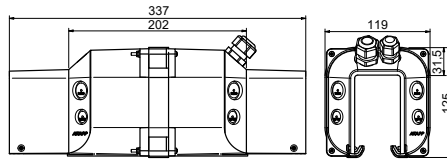

LBS

Type LB40

Line feed box for connection of copper conductors up to 125A. With 1 gland M40 for cables Ø22-Ø27 mm.

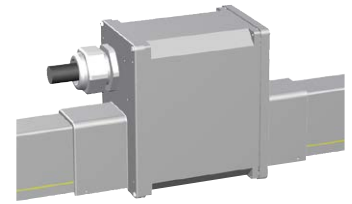
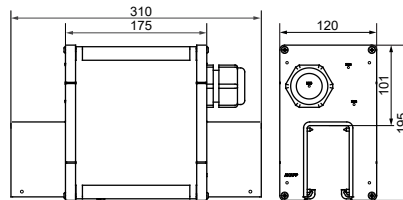

LB40/LB63

Type LB63

Line feed box for connection of copper conductors up to 160A. With 1 gland M63 for cables Ø37-Ø44 mm.

See table with part no's on page 6.

Line feed clamp holders

Type RN7-LCH

Applicable for line feed connections with continuous copper (all sizes), irrespective the number of poles.

The required line feed clamps have to be ordered separately.

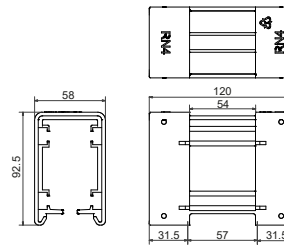

RN4-LCH

Type RN-LH

Applicable for line feed connections with continuous copper that require joints in the line feed (i.e. in multi curved systems, very long tracks etc.).

The RN-LH is composed of 2 halves that "click" together around the rail housing leaving the copper joints free. Includes bolts/nuts M6 for connections of conductors.

See table with part no's on page 6.

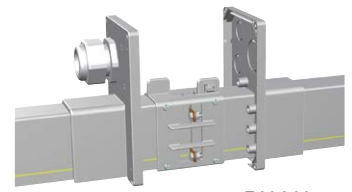
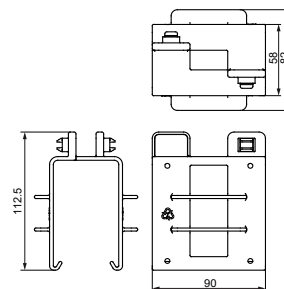

RN-LH (mounted)

Feed clamps

Type LC80

To be applied for mounting copper conductors Cu35 - Cu80.

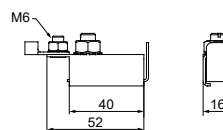

LC80

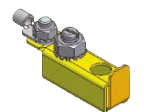

Type LC200

To be applied for mounting copper conductors Cu125 - Cu160.

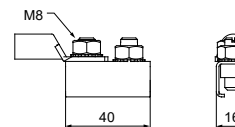

LC200

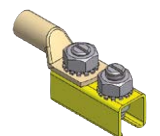

AKAPP NO.	DESCRIPTION	QUANTITY	Imax. (A) 100% D.C.
1012750	Feed clamp small LC80	1 per conductor	73
1013000	Feed clamp LC200	1 per conductor	179

Collector trolleys

economic collector trolleys series C4

In a 4-Ductor system, the collector trolleys type C(L)4 are used as standard, suitable for indoor and outdoor installations with up to 4 conductors. The 70A and 100A types are made up of 2, respectively 3 separate collector trolleys which are mounted on a metal strip (see the figures below).

All collector trolleys can be delivered without or with 1 m supply cable (type "C4-...", resp. "CL4-...").

It is recommended to use a transition box when connecting the trolley with the apparatus to be fed. This box (order separately) can be mounted on the towing arm (see figure below and on page 11).

These collector trolleys are supplied with Nylon wheels, suitable for **traverse speeds** up to **60 m/min**. For **higher traverse speeds** and for **heavy duty environments** you should use collector trolleys of series 'C(L)7-...'. See page 9 for more details.

Standard collector trolleys

Series C4 collector trolleys are available for 4 conductors with current carrying capacities of **35A, 70A and 100A** (D.C. 60%).

Applicable from -20 °C up to +80 °C.

Collector trolleys type CL4 are fitted as standard with a supply cable. The connection with the apparatus/machine to be fed is via a transition box, to be ordered separately (see below).

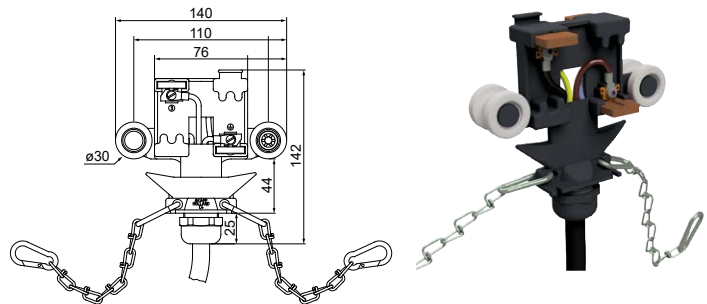

CL4-35

Carbon brushes

The collector trolleys type CL4 are supplied as standard with carbon brushes for 35A, according to the table below.

CARBON BRUSH TYPES *)			Standard brushes
AKAPP NO.	Application	Brush position in collector trolley	for normal conductors
1411021	Phase brush compl.	1, 2 and 3	K91P
1410521	Earth brush compl.	4	C91A

*) also applied in CL7 collector trolleys (page 9)



CL4-70

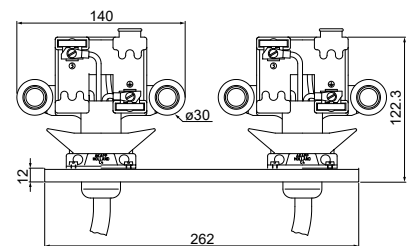

Transition boxes for collector trolleys

This unit facilitates the connection of the flexible cable from the collector trolley with the fixed wiring from the apparatus/machine being fed.

Using the included attachments, the transition box can be mounted easily on the (Akapp-Stemmann) towing arm or close to the apparatus/ machine.

Types of transition boxes:

AKAPP NO.	DESCRIPTION	
1020000	Transition boxes for collector trolleys	TTB35-4
1020020	Transition boxes for collector trolleys	TTB70-4
1020040	Transition boxes for collector trolleys	TTB100-4
1010430	Transition boxes for collector trolleys	OG300-7

See page 11 for further information and dimensions.



CL4-100

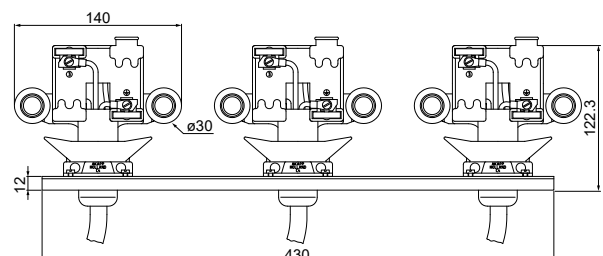

TTB35-4

TTB70-4

TTB100-4

Collector trolleys

adaptions for special applications

In addition to the standard C(L)4 series current collectors, the RN4 conductor bar system can also be used with the C(L)7 series current collectors (for more information, see the brochure 'Multiconductor').

This is necessary in any case for installations with **high travel speeds (up to 250 m/min.)**, **expansion joints** and/or **curves**. These collector trolleys are supplied with wheel sets specially adapted for these installations.

These wheel sets are also available separately and can be easily fitted. The type designation that applies to this is shown in the table below.

For the applied **carbon brushes**, see the table on page 8.

Wheel sets for special applications

There is a number of possibilities to adapt the standard current collector trolleys series CL7. Wheel sets are available that can be mounted or exchanged easily by means of dove-tail connections (see photo).

In the table below a number of special performances is listed with its respective suffix.

In cases not covered by the table, please contact your Akapp-Stemmann supplier.

Collector trolleys for installations with expansion joints

Type CL7-4-35/E

For installations with expansion joints (KEV7), a CL7 collector trolley with additional wheel is necessary (see table). This allows the expansion gap in the sleeve to be passed through. These **bearing-mounted** wheels can be recognized by the **blue** color (see image).

Collector trolleys for high travel speeds

Type CL7-4-35/S/(T)

For installations where the driving speed is >60 m/min. and maximum 250 m/min. CL7 collector trolleys with wheel sets with **bearings** are required (see table). These wheels can be recognized by their **blue** color (see image on the right). Depending on the circumstances, also **top wheels (T)** can be used. Consult your Akapp-Stemmann supplier for this.

Collector trolleys for curves

Type CL7-4-35/(S)/T/Z/(E)

Collector trolleys with this wheel set can be used for installations with curves with radius **from 800 mm**. In many cases an extra wheel (/E) is therefore necessary (see above), e.g. when using expansion joints (KEV7).

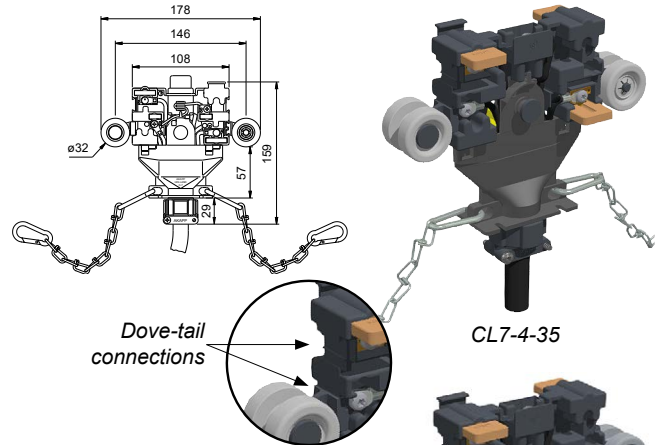

Dove-tail connections

CL7-4-35

Extra wheel (./E)



Running wheels, beared (./S)

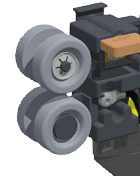

Top wheels, not beared (./T)

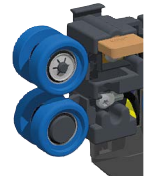

Top wheels, beared (./S/T)

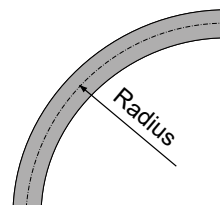

Curved section RN4 (top view)



Top wheels, side wheels and extra wheel (./T/Z/E)



Top wheels and side wheels, beared (./S/T/Z)

AKAPP NO.	ADAPTION COLLECTOR TROLLEY	TYPE
1093450.B0000	Running wheels, beared *)	CL7-4-35/S
1093460.B0000	Extra wheel, beared	CL7-4-35/E
1093470.B0000	Top wheels	CL7-4-35/T
1093480.B0000	Top wheels, beared	CL7-4-35/S/T
1093440.B0026	Top wheels, side wheels and extra wheel	CL7-4-35/T/Z/E
1093480.B0001	Top wheels and side wheels, beared	CL7-4-35/S/T/Z
1093480.B0002	Top wheels, side wheels and extra wheel, beared	CL7-4-35/S/T/Z/E
1093440.B0001	Special cable length 3m	CL7/4/35/3M
1093440.B0004	90 degree gland	CL7/4/35/HWK

*) travel speed up to 250 m/min.

Collector trolleys series CL4-40

the compact solution for double brushes per phase

Type CL4-40 is a singular collector trolley with double carbon brushes per phase and is used for conditions in which double carbon brushes must be used in conductor bar systems.

For those cases, the CL4-40 trolley is a good and cost effective solution.

In addition, the CL4-40 will improve the cost effectiveness of systems that are controlled by frequency inverters.

The CL4-40 is a 4 pole trolley, capacity 40 Amps at 60% duty cycle at 50 °C. Applicable from -20 °C up to +50 °C.

The CL4-40 uses twin carbon brushes C91D for phases and special twin ground brushes C91DA.

All CL4-40 trolleys are available with cable lengths of 1, 3 or 5 m. For standard cable length 1 m, the indication is /1M. For other cable lengths add /3M or /5M to the type description.

Standard collector trolleys

Type CL4-40

4-pole trolley with standard wheels.

Max. speed 100 m/min.

For all RN-types of housings.

Standard fitted with 1m cable.

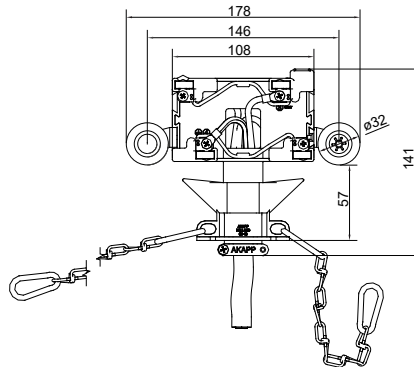

CL4-40

Type CL4-40/S

4-pole trolley with ball beared wheels.

Max. speed 250 m/min.

For all RN-types of housings.

Standard fitted with 1m cable.



CL4-40/S

Note: Trolleys without cable are also possible. Please cancel the "L" in the type description; e.g. type 'C4-40' is a 40 Amps trolley without cable.

Carbon brushes and wheel sets

The following parts are applicable:

AKAPP NO.	DESCRIPTION	TYPE
1410601	Carbon brush twin phase	C91D *)
1410631	Carbon brush twin ground	C91DA
1630100	Wheel set standard (grey)	W *)
1630110	Wheel set high speed (blue)	WS *)



Wheel set W

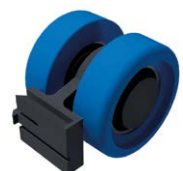

Wheel set WS

*) similar as on CL7 collector

Transition boxes for collector trolleys

This unit facilitates the connection of the flexible cable from the collector trolley with the fixed wiring from the apparatus/machine being fed.

Using the included attachments, the transition box can be mounted easily on the (Akapp-Stemmann) towing arm or close to the apparatus/ machine.

See for further information and dimensions page 11.

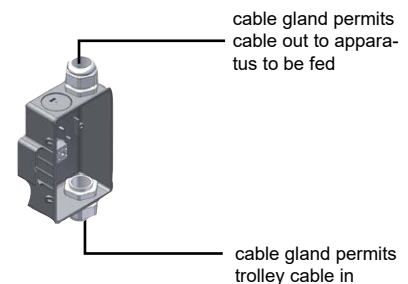

TTB35-4

cable gland permits cable out to apparatus to be fed

cable gland permits trolley cable in

AKAPP NO.	DESCRIPTION	EXTENSIONS		max. I _n (A) (D.C.=100%)	number of poles	max. speed (m/min)	expansion joint (KEV)	APPLICABLE FOR			
		ext. 1	ext. 2					dust proof	acid proof	data silver-red	vertical curves
1088600	Collector trolley + cable	/1M		31.00	4	100	-	-	-	-	-
1088600.B0003	Collector trolley + cable CL4-40	/3M		31.00	4	100	-	-	-	-	-
1088600.B0005	Collector trolley + cable CL4-40	/5M		31.00	4	100	-	-	-	-	-
1088620	Collector trolley + cable CL4-40	/S	/1M	31.00	4	250	-	x	-	-	-
1088620.B0003	Collector trolley + cable CL4-40	/S	/3M	31.00	4	250	-	x	-	-	-
1088620.B0005	Collector trolley + cable CL4-40	/S	/5M	31.00	4	250	-	x	-	-	-

Accessoires for collector trolleys

towing arms, transition boxes

A towing arm is attached to the moving machinery and connected to the collector trolley via chains.

The arrangement is such that when pulling in either direction one of the collector towing chains is taut, the other remaining slack. In this way lateral movements of the crane, hoist, etc. are not transmitted to the trolley.

This tolerance provides ultimate **security of service!**

Attention: The towing connector on the arm should be installed 10 mm lower than the towing connection on the trolley in the highest position and at 30 mm lower than the towing connection on the trolley in the lowest position and should be aligned directly below the housing opening in the vertical plane.

A transition box can be mounted on the towing arm or close by the apparatus/machine. This unit facilitates the connection of the flexible cable from the collector trolley with the fixed wiring from the apparatus/machine being fed.

Standard performances of towing arms

AKAPP NO.	TYPE	for collector trolleys
1019050	BMV35	35A / 40A
1019130	BMV70	70A
1019210	BMV100	100A

Dimensions of towing arms with transition boxes

DIM.	BMV35 + TTB35	BMV70+ TTB70	BMV100 + TTB100
A	370	505	640
B	175	175	195
C	115	115	160
D	70	70	80
Input	1xM32	2xM32	3xM32
Output	1xM32	1xM40	1xM40

See the drawing on the right

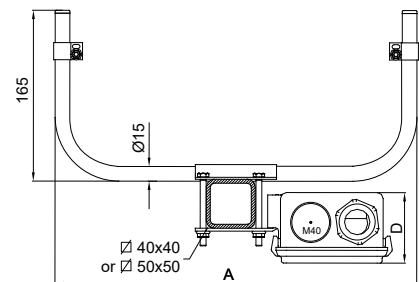

BMV + TTB

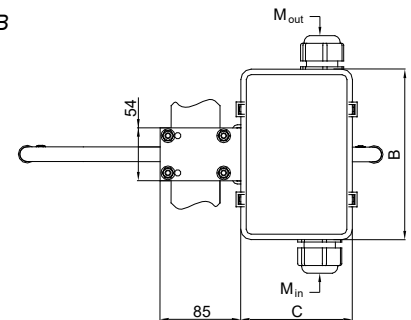

Transition boxes for collector trolleys

AKAPP NO.	type of transition box	dimensions l x w x h mm	connecting terminals	cable inlet
1020000	TTB35-4	175x115x70	4 st. 4 mm ²	2 glands M32
1020020	TTB70-4	175x115x70	4 st. 10 mm ²	2 glands M32 1 gland M40
1020040	TTB100-4	195x160x80	4 st. 16 mm ²	3 glands M32 1 gland M40
1010430	OG300-7	300x190x180	7 st. bolts M10	6 glands PG21 1 special inlet 20-70 mmØ

The box types TTB35 up to TTB100 can be mounted directly on the fastening clamp of the towing arm type BMV. Box type OG300 is supplied with a mounting plate, which ensures easy mounting of these boxes to the apparatus to be fed.

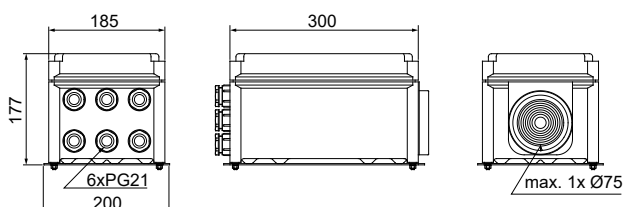

OG300-7

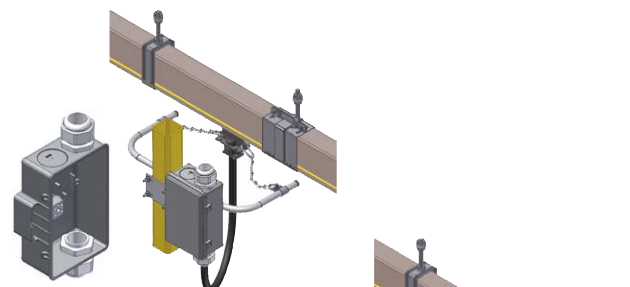

BMV35 + TTB35-4

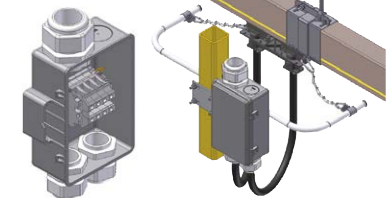

BMV70 + TTB70-4

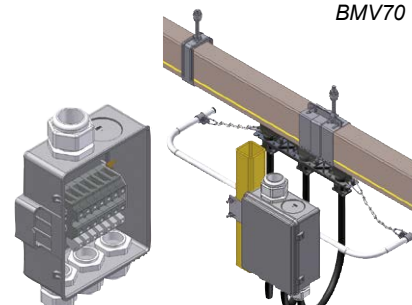

BMV100 + TTB100-4

Installation tools

for optimal efficiency

Akapp-Stemmann 4-Ductor can easily be installed. All components have been designed as such that a combined installation is perfectly suitable.

However several operations during the installation process may be arranged even more efficient if you should opt for the auxiliary tools as detailed below. Therefore, we strongly recommend you to add these tools to the delivery (refer to the relevant product).

It is of importance to use the products as detailed below, whenever possible. You could save time. Read the instructions carefully and prior to the use of said products.

Should you have any questions, please feel free to contact your Akapp-Stemmann supplier. Further information can be obtained via our web site www.akapp.com as well.

Our Service Department could ensure the perfect installation of your 4-Ductor, if so required. We would be pleased to submit a fitting quotation!

Copper pulling-cassette

This device can be included in all new installations of the 4-Ductor.

The copper rolls are placed onto the cassette after which the roll will be rolled off smoothly. The roll is provided with a feed-through aperture. A limiter prevents the rolling off of the roll onto the platform.



Copper drawing block

In order to smoothen the drawing of the copper conductor into the copper channels of the 4-Ductor, a wooden drawing block can be included in all new complete installations. This drawing block includes a drawbar eye into which a rope can be attached. To be used in combination with the aforementioned copper pulling cassette.



Copper guide strip for KEV

Plastic strip for easily pulling in copper conductors CU50 in 4-Ductor systems where expansion joints (KEV) are applied (see also page 5). See picture next.



Copper straightener

It is strongly recommended to use this tool for the easy mounting of the copper conductors 125A and 160A in the 4-Ductor. The stretcher eliminates the ridged form of the copper during the mounting thereof. This is mainly of importance with regard to track lengths from approximately 50 meter.



Wooden wedge set (OBA)

For fast taking out and inserting trolleys at almost any location of the 4-Ductor system. The set consists of two wooden wedges with two pvc plates. By inserting the wedges into the housing and then turning it, the housing will widen and the trolley can be taken out easily. When inserting the trolley again, the two plates can be used to guide it into the housing.

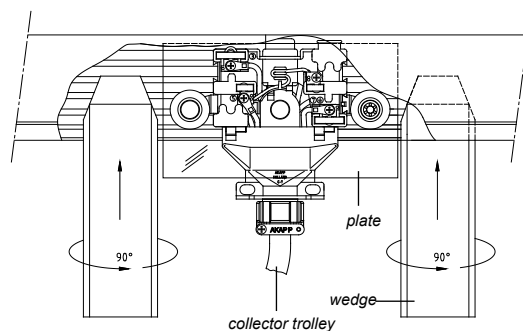

AKAPP NO.	DESCRIPTION	length >25m	CU 125	CU 160
1003610	Drawing block for conductors	x		
1003850.E0000	Copper guide strip for KEV			
1003920	Straightning device STR125 for CU125	x	x	
1003950	Straightning device STR125 for CU160	x		x
1040530	Wooden wedge set (OBA)			

AKAPP NO.	DESCRIPTION	length >25m	inner core ø mm	max. outer-ø Cu mm
1039820	Copper cassette 50x50 cm compl	x	245	450
1040220	Copper cassette 80x80 cm compl	x	455	750
1040450	Copper cassette 100x100cm cpl	x	455	950

4-Ductor system configuration

A. Installation with end feed box (EB..)

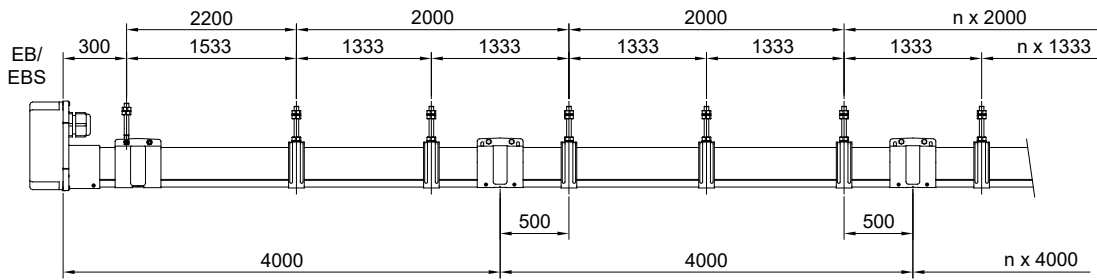

B. Installation with line feed box (LB..)

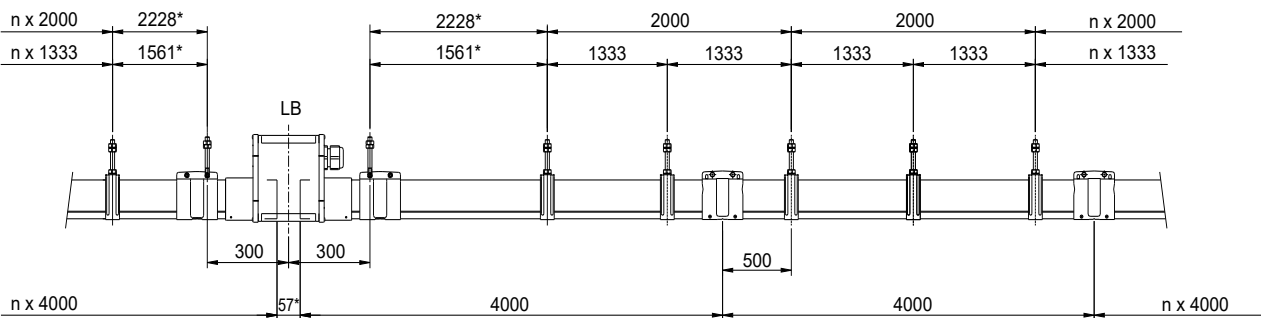

When clamp holder RN-LH is applied: 57 = 0 mm; decrease other dimensions marked with * by 28 mm

Note:

In the examples above there are two possibilities shown for the centre distance of the support hangers. We recommend:
 1333 mm: all installations
 2000 mm: only possible when copper conductors max. 80A are used

Mounting detail end feed box and trolley towing arm

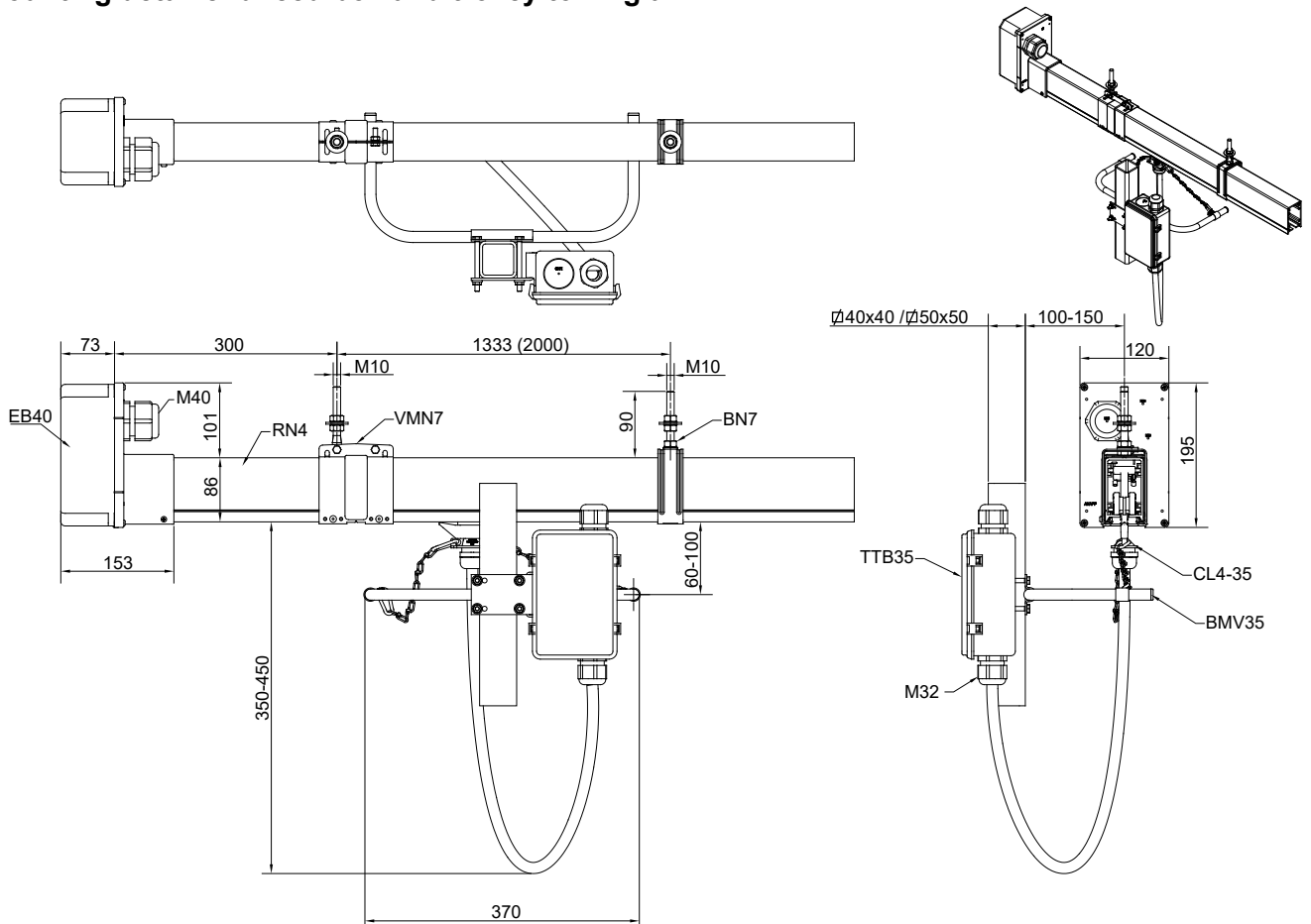

Akapp-Stemmann Service Department

perfect installation, preventive maintenance

Akapp-Stemmann 4-Ductor can be installed quickly and easily due to the well-matched components and the modular construction. The necessary instructions are included with each installation and, of course, we can advise you further on the procedure to be followed if desired.

You can also have our **Service Department** take care of the **installation** of your system(s). Our experienced and expert engineers take all the work off your hands and ensure perfectly functioning system(s).

Planning and preparation

If you want our Service Department to install an Akapp-Stemmann system, we will coordinate our activities in close consultation with you. First of all, this requires planning. It is very important that when the work has to be carried out, the location is easily accessible, the materials to be installed can be delivered to the location (or are already available) and that safety is guaranteed for both your and our staff. Any climbing equipment (ladders, scaffolding, etc.) must also be able to be used at the location where necessary.

Naturally, your current business processes must be hindered as little as possible during installation. We therefore make **clear agreements** with you in advance about the planning of the work, so that no undesirable situations arise.

Installation can, if necessary, also be carried out outside normal office hours; also on weekends. The special conditions that apply to this will be discussed with you in advance. We also consult with you in advance about any safety instructions that need to be followed at your location.

Which materials must be installed is in most cases determined in the installation quotation, which we will send you based on your request. It also specifies everything about the mounting conditions.

Mounting activities

Our experienced engineers are equipped with professional aids and tools and ensure fast and perfect installation, which will fully meet the specifications agreed with you in advance. All components are mounted in accordance with the regulations. This is very important with a view to the **reliability** and **safety** of the installation and the **lifespan** of the components.

It goes without saying that a guarantee can only be given on a system that has been installed and used in accordance with the regulations.

Would you like to have the installation of one or more 4-Ductor systems carried out by our Service Department? You can request this through our Sales Department. We provide a suitable offer.

We are also happy to take care of the **maintenance** of your existing installation(s). We keep your installation(s) in excellent condition through a thorough inspection and possible replacement of wearable parts.

If desired, we will conclude a maintenance contract with you, in which all activities and terms are agreed with you.



Maintenance

Every installation needs (periodic) maintenance in order to continue to function reliably and this also applies to the Akapp-Stemmann 4-Ductor system.

It is therefore very important that periodic **preventive inspection** and **maintenance** is carried out. The periods within which this must be done depend on the operating conditions and intensity of use of the relevant installation(s).

Wearable parts, such as carbon brushes and trolley wheels, can be replaced during this work before a failure can occur. The condition of other vital parts, such as suspension brackets, connecting joints and copper conductors, must also be carefully checked and repaired where necessary.

You can also call in our Service Department for inspection and maintenance. We know exactly which systems are present at the relevant location and, with the right preparation, we can carry out maintenance as efficiently as possible. Of course we will coordinate with you when it suits you best to prevent or minimize any disruption to your other business processes.

When you conclude a **maintenance contract** with us, we ensure that you are automatically approached by us when the next maintenance is due. You no longer have to worry about this and your systems remain in the best possible condition!

We are happy to inform you about all the possibilities of our Service Department.

Akapp-Stemmann conductor bar systems

always a perfect solution!

The AKAPP 4-Ductor is an ultimate reliable and efficient conductor system, which is world-wide, successfully used in a large number of installations.

This brochure details a brief outline of the unique characteristics.

However, Wabtec Netherlands supplies many conductor systems, a fitting solution for the most diverse situations, also if accurate positioning is necessary!

Wabtec Netherlands aims to provide all information you need: our professional team is available for free and non committal advice.

Further information required? Just a telephone call or e-mail will suffice. Please see the front cover for details or check www.akapp.com to find your nearest distributor.

Multiconductor

A compact and multi purpose conductor system. The **uninterrupted** conductors ensure a perfect transmission of **current feed-** as well as **control-** and **data signals**. Current capacities up to 320A. A flexible rubber sealing prevents penetration of dust or liquids. Well suited for extremely long tracks and high travel speeds. Used world-wide for cranes, traverse cars, (automated) warehouses, elevators, textile production, sluices, trains etc., even under in extremely dusty, humid or even corrosive environments!

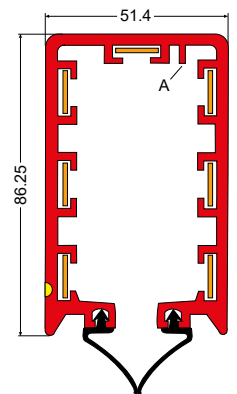

Power-POZ

Conductor rail with integrated non-contact semi-absolute **positioning system**, developed for use in demanding crane and production installations, such as overhead cranes, the agricultural sector (feeding/spreading robots) and prefab concrete production. The profile has 5 channels for **power supply** up to **160A** and 2 channels for **positioning** by means of a sensor trolley and magnet positioning strip(s).

Maximum length 260m. For longer tracks, a second magnet positioning strip is installed in the opposite channel and a second sensor trolley is used. This makes the maximum **track length** with positioning **520m**.

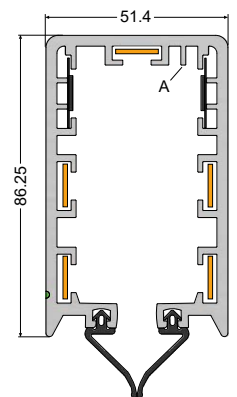

Pro-Ductor

The most compact, varied conductor system for automated warehouses and many other applications! Suitable for up to 4 (type PR4), 7 (type PR7) or 10 (type PR10) copper conductors. The p.v.c. housing PR7 has a height of only 147 mm and is 27 mm wide and can be applied only centimetres above floor level.

The **uninterrupted** conductors ensure a perfect transmission of both **feed, control and data signals**. Choices in current capacity from 50A, 80A, 125A, 160A up to 200A.

Suitable for **extreme long travelling lengths** and **high travel speeds**.

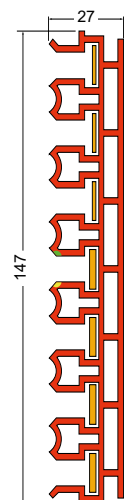

Wabtec Netherlands: Flexible with energy!



Wabtec Netherlands is a market leader with our made to order conductor bar systems. We offer you the best possible solution for almost any application in whatever the circumstances. We welcome your inquiries!



Our cable reels prove their worth daily in numerous applications, indoors as well as outdoors. Reliable power consumption and control for cranes, hoists, internal transport carts, electrical tools etc. We can also supply the correct high-flexible cable to meet your needs!



Our festoon systems offer extensive options for the safe and efficient transport of your cables. Thanks to the high quality and reliability, you can use it for situations, both indoors and outdoors.



Akapp-Stemmann products are designed by the highest standards and are certified by UL, CCC and/or CE.

More information on our products can be found in our brochures, which we are happy to send you on request. Or visit our website www.akapp.com, where you can find more relevant information, download brochures and make online inquiries; fast and easy!

